



US 20090125121A1

(19) **United States**

(12) **Patent Application Publication**
PERKINS et al.

(10) **Pub. No.: US 2009/0125121 A1**

(43) **Pub. Date: May 14, 2009**

(54) **ATTACHMENT SYSTEM FOR PROSTHESIS INCLUDING AXIAL TENSION STRAP ATTACHED TO SOCKET LINER**

Publication Classification

(76) Inventors: **DALE PERKINS**, TWIN FALLS, ID (US); **MATT PERKINS**, BOISE, ID (US)

(51) Int. Cl.	
<i>A61F 2/78</i>	(2006.01)
<i>A61F 2/74</i>	(2006.01)
<i>A61F 2/80</i>	(2006.01)
<i>A61F 2/60</i>	(2006.01)

Correspondence Address:
PEDERSEN & COMPANY, PLLC
P.O. BOX 2666
BOISE, ID 83701 (US)

(52) **U.S. Cl.** **623/33; 623/27; 623/36; 623/31**

(21) Appl. No.: **12/247,179**

(57) **ABSTRACT**

(22) Filed: **Oct. 7, 2008**

An attachment system secures a residual limb to an artificial limb in a comfortable and substantially non-rotational manner. The attachment system offers proximal anchoring of the residual limb in a hard socket, by connecting a side surface of a residual limb liner to the side surface of the socket. Preferably, this connection is accomplished using an extension member extending from the liner through a portion of the socket interior, through the socket wall, and attaching to a latch mechanism. The preferred attachment system requires no clearance in the bottom of the socket well because neither the extension member nor the latch mechanism is located between the distal end of the residual limb/liner and the bottom of the well. The attachment system is preferably disposed entirely along the side of the limb and the side of the socket.

Related U.S. Application Data

(63) Continuation of application No. 11/234,063, filed on Sep. 23, 2005, now Pat. No. 7,431,738, Continuation-in-part of application No. 10/746,208, filed on Dec. 23, 2003, now Pat. No. 7,077,868, which is a continuation-in-part of application No. 09/972,729, filed on Oct. 4, 2001, now Pat. No. 6,666,894.

(60) Provisional application No. 60/238,301, filed on Oct. 4, 2000.

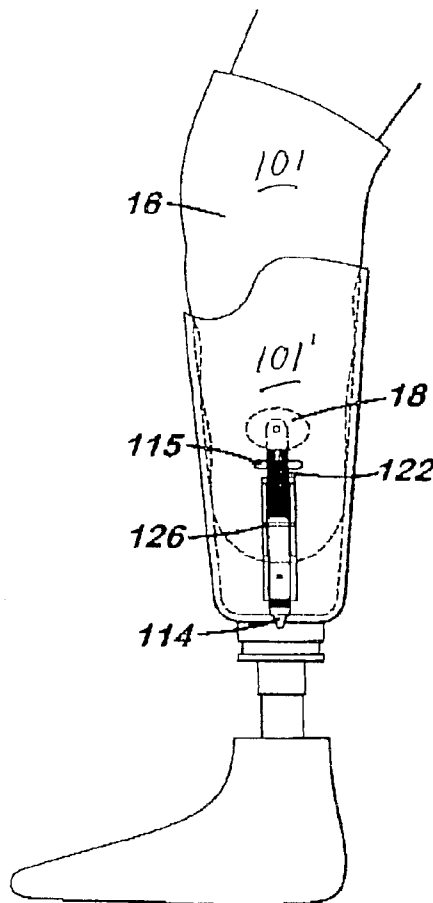

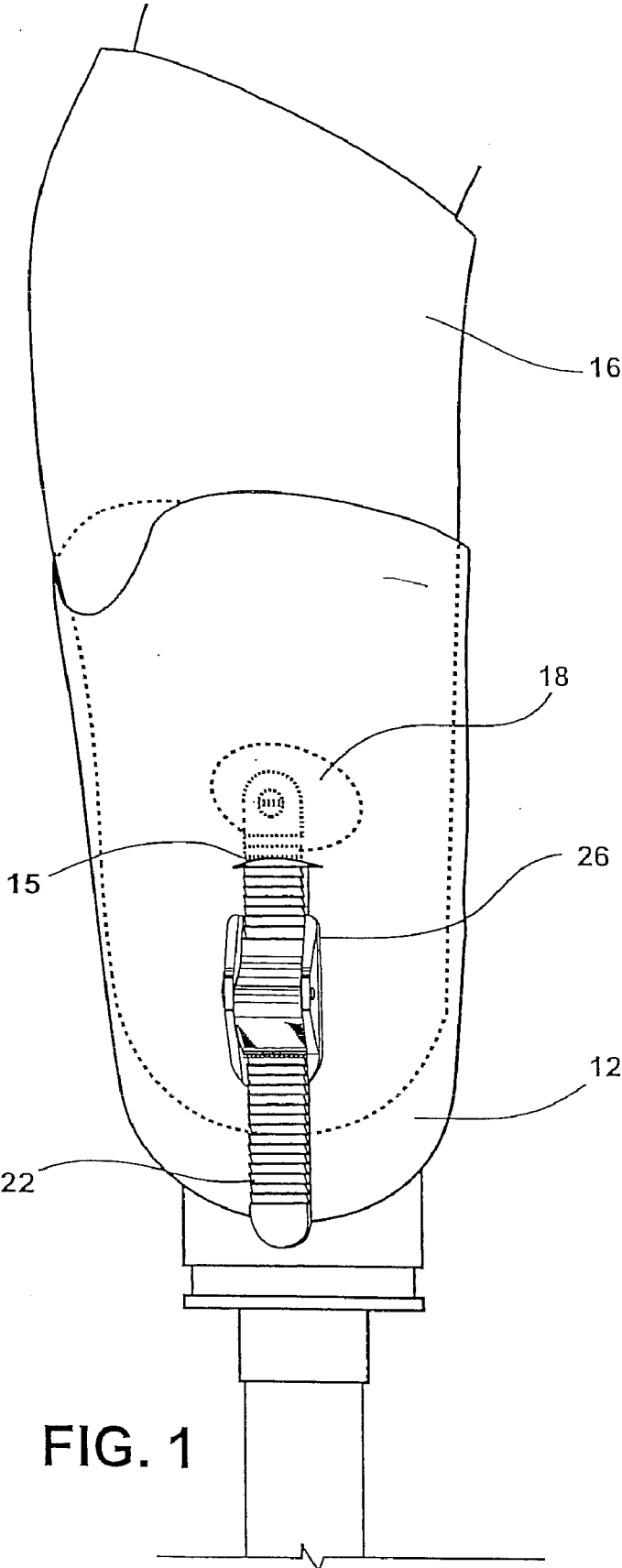

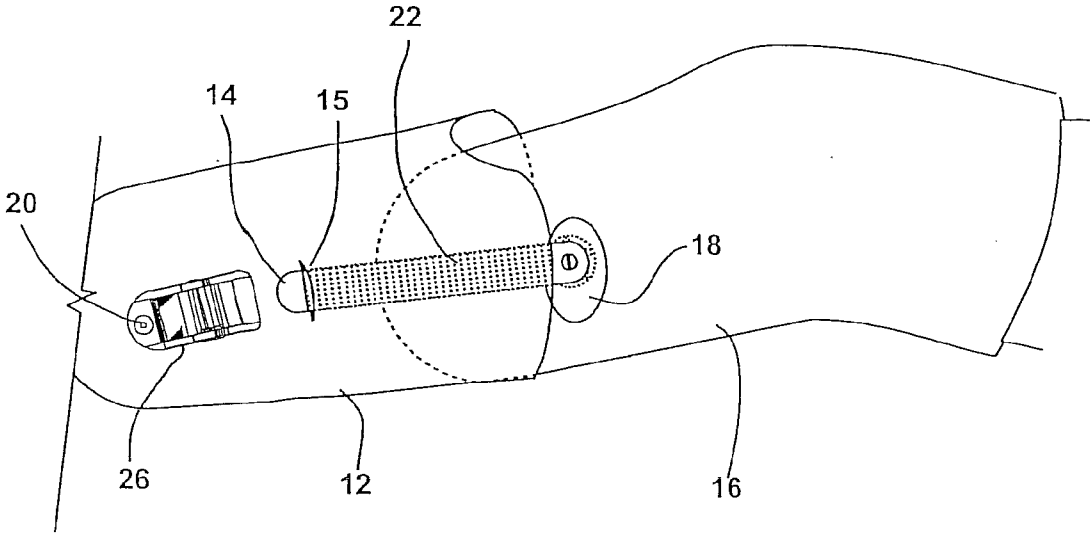
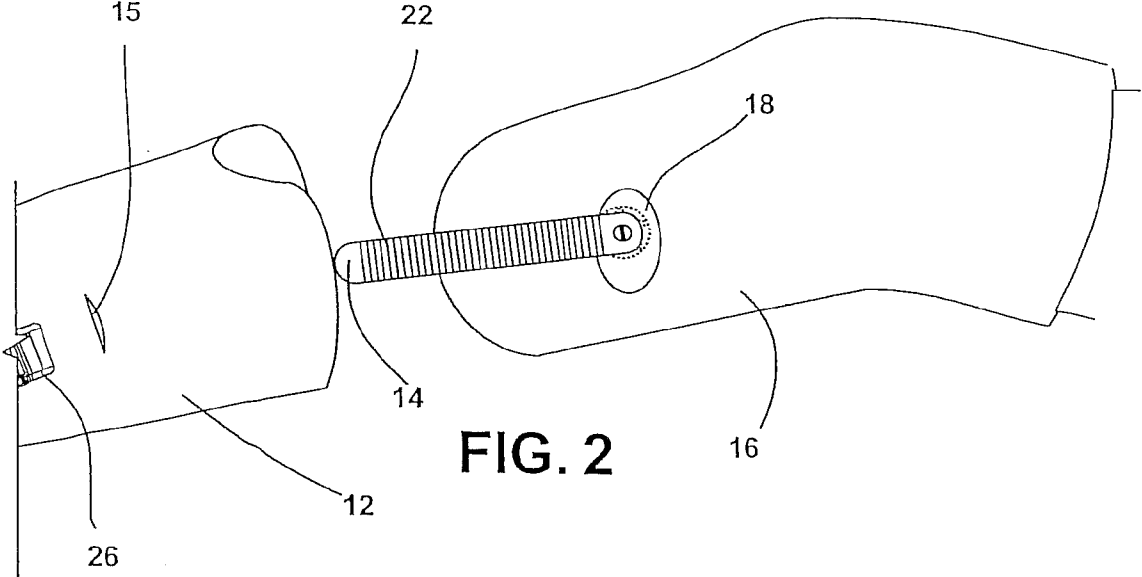

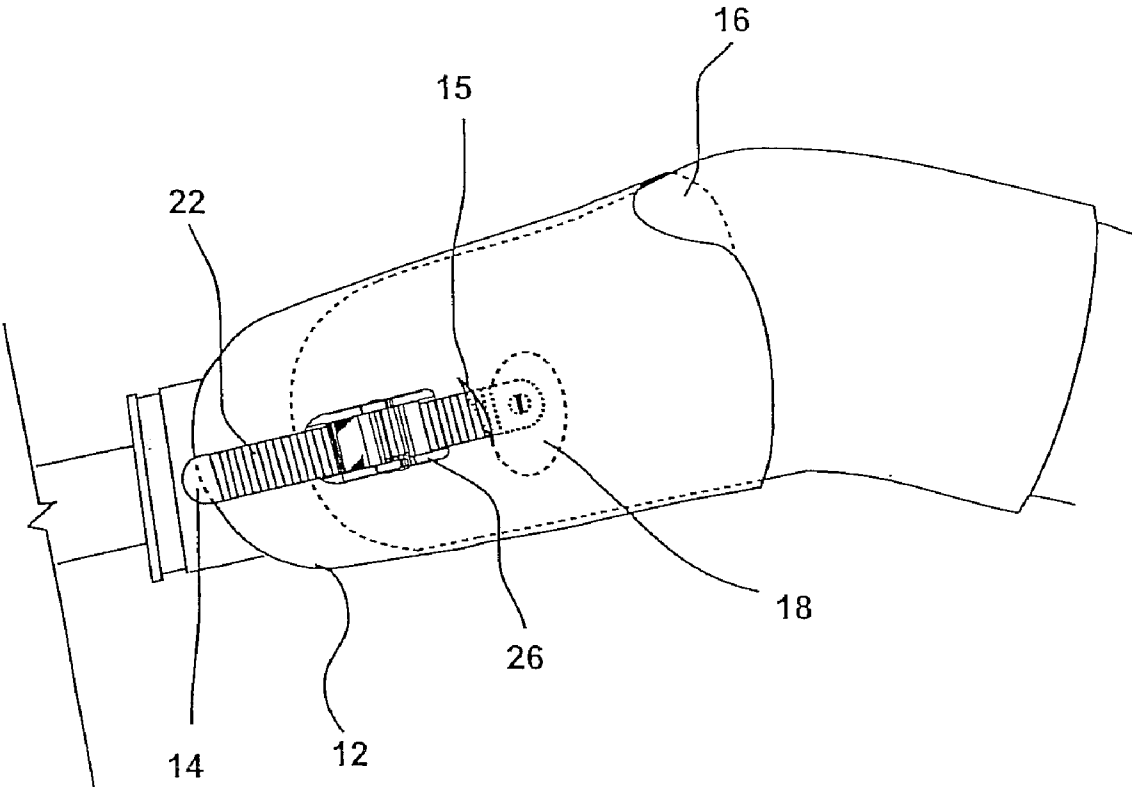

FIG. 4

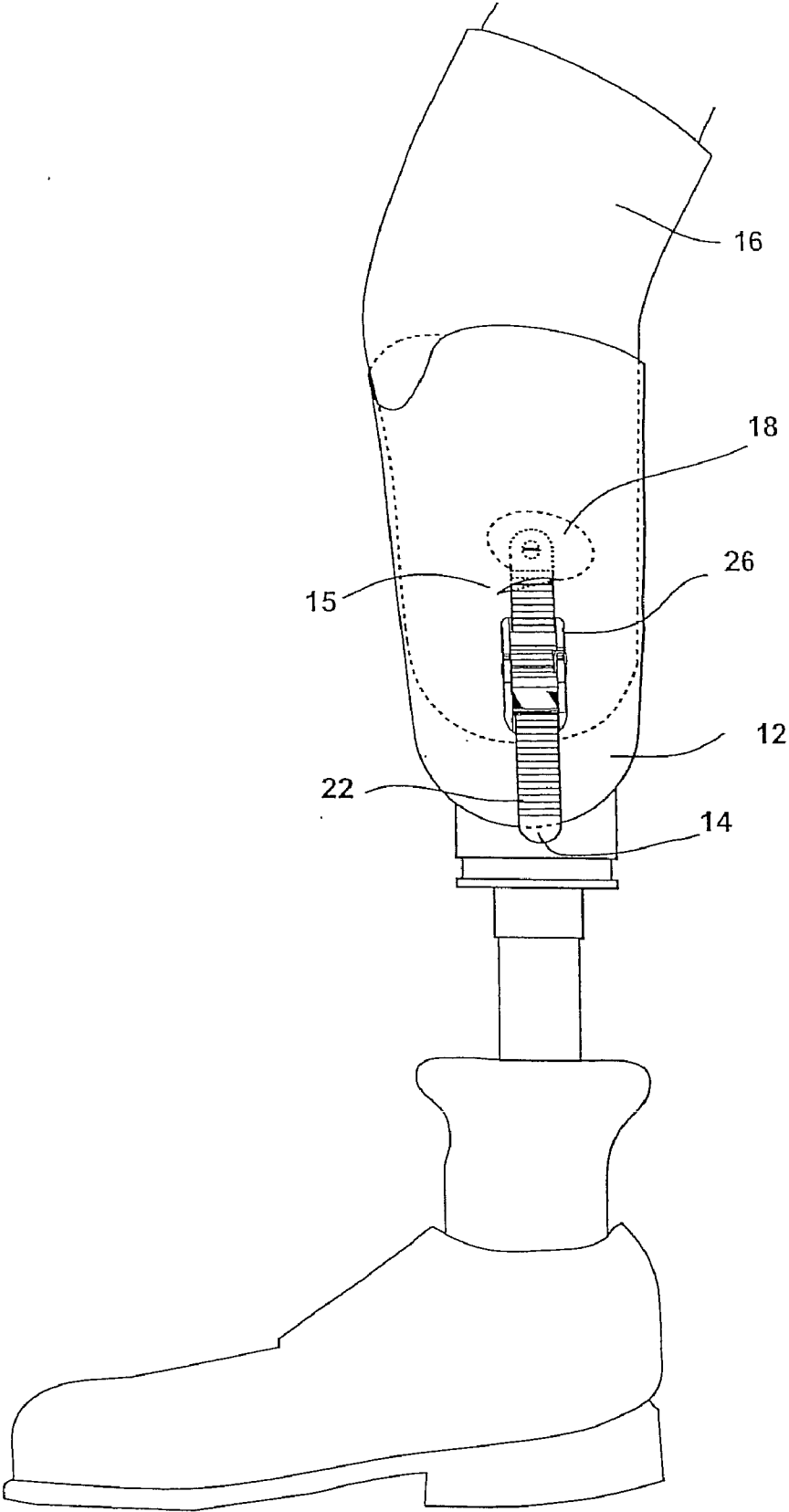
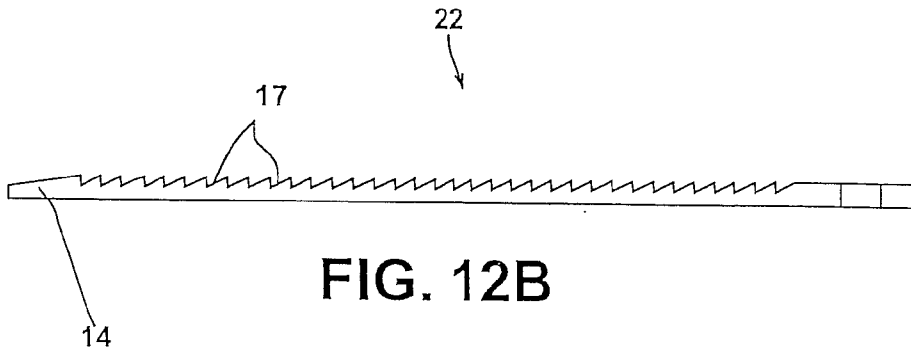
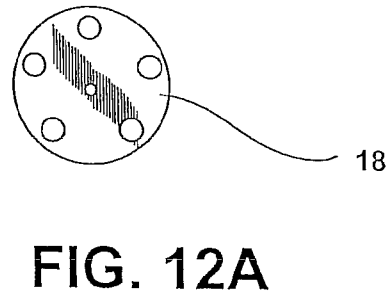
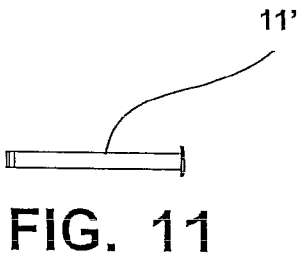
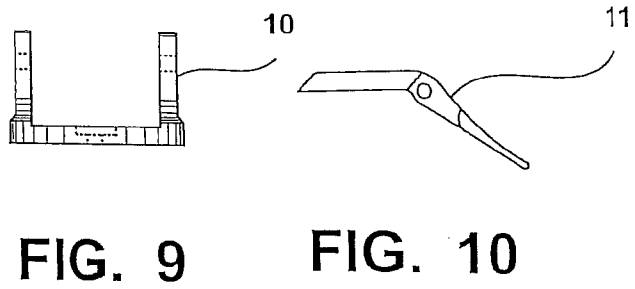
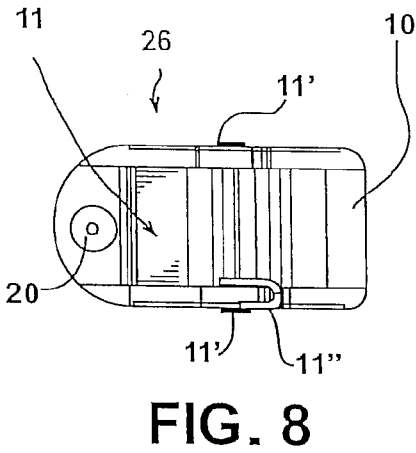
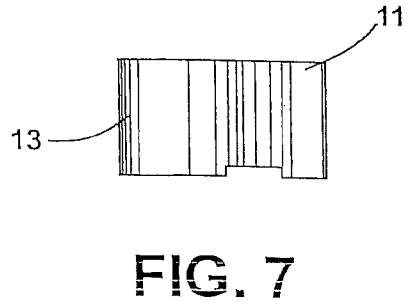
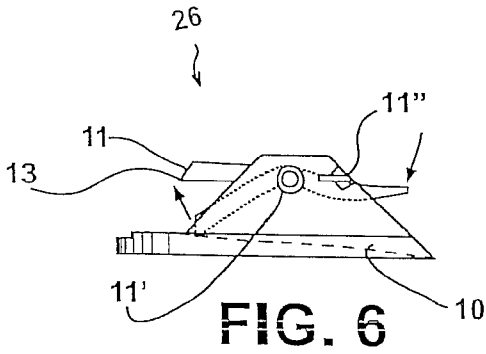

FIG. 5



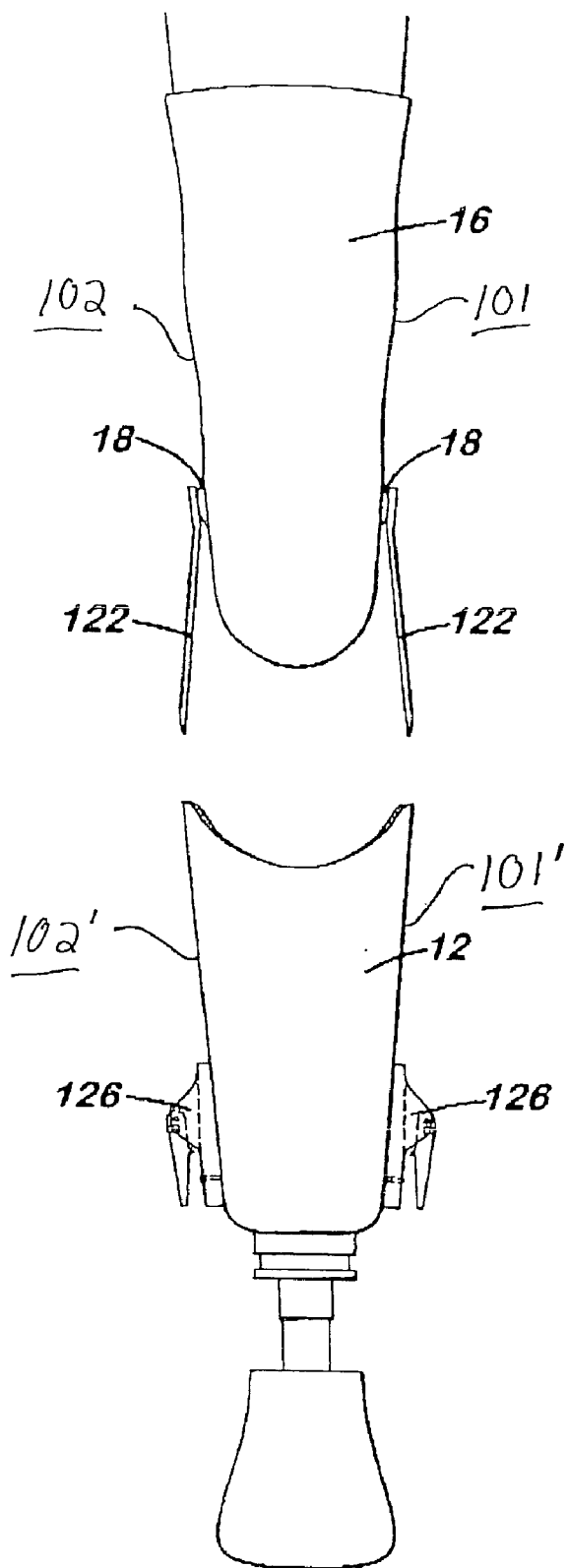

Fig. 13

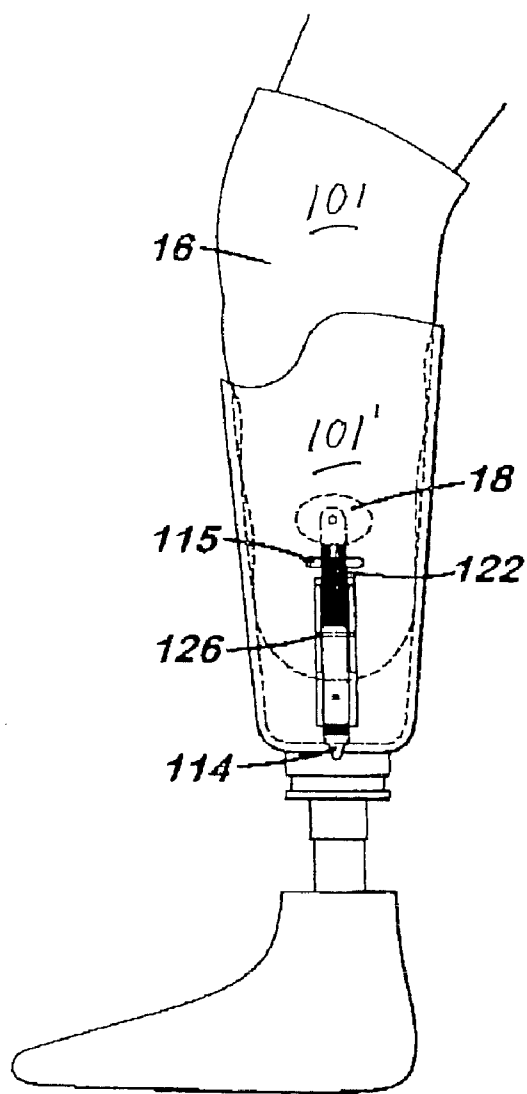

Fig. 14

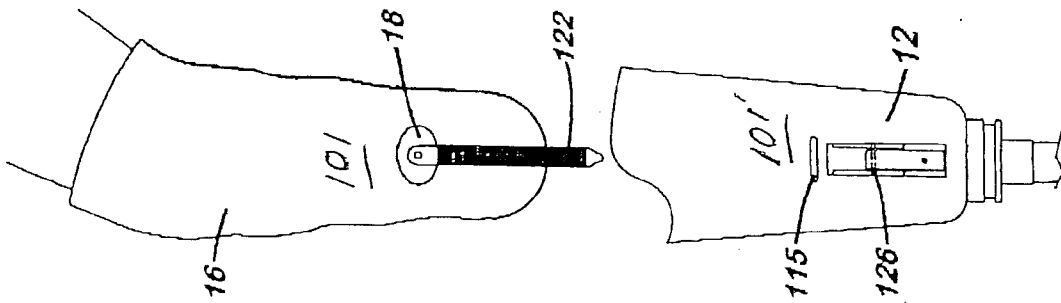

Fig. 15

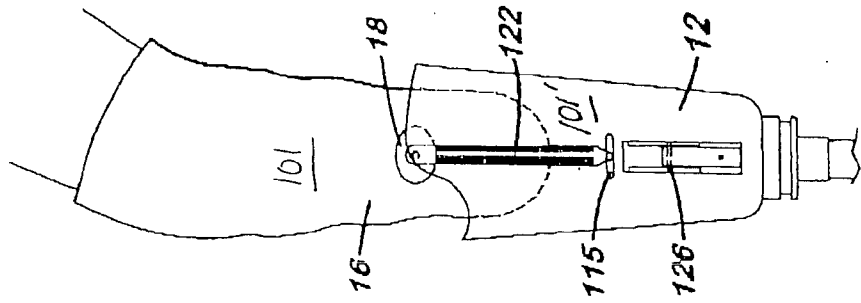

Fig. 16

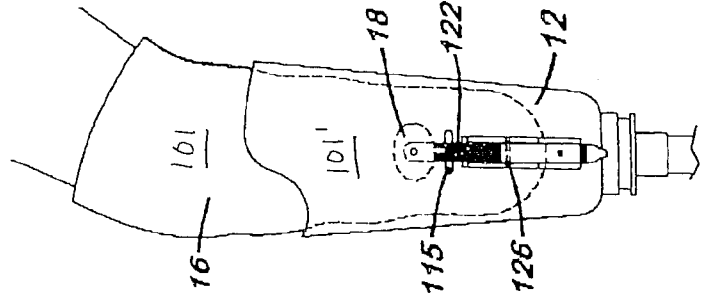

Fig. 17

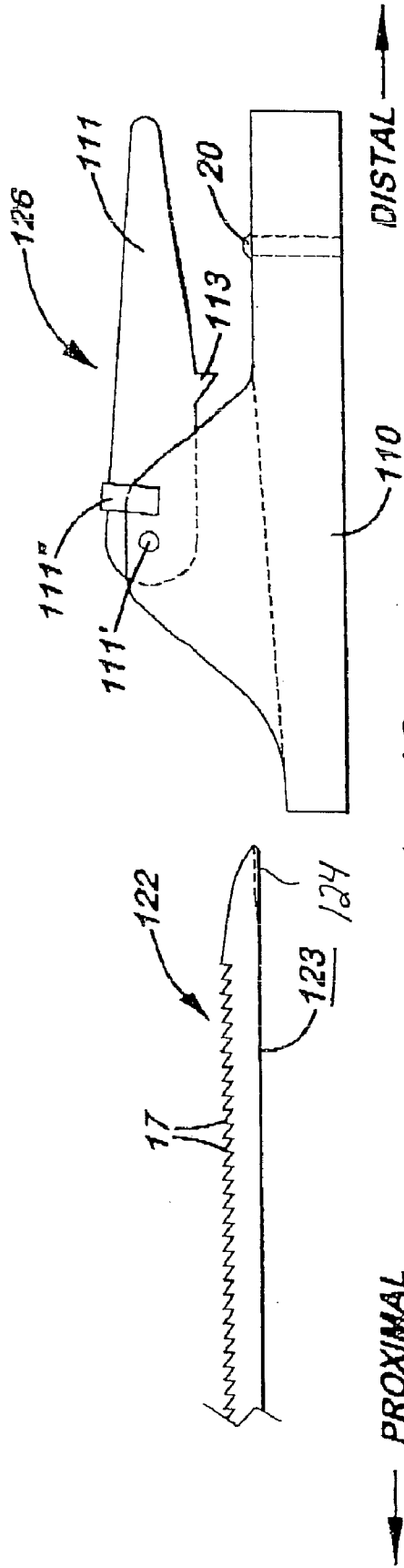

Fig. 18

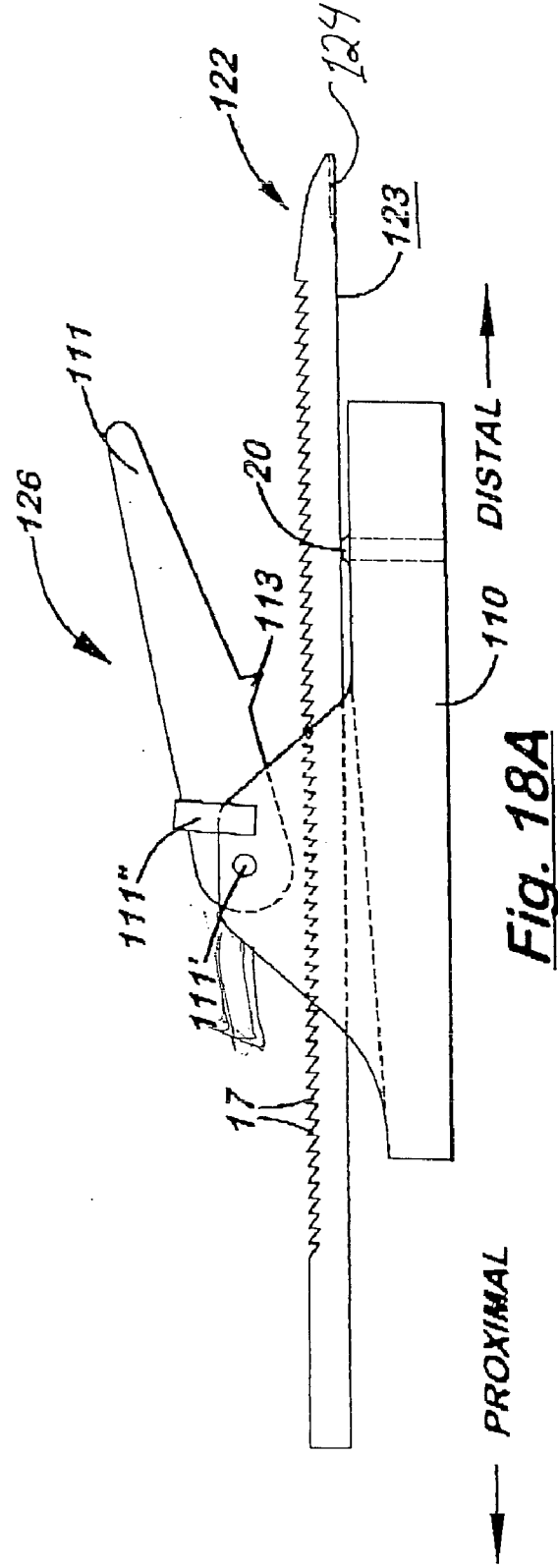

Fig. 18A

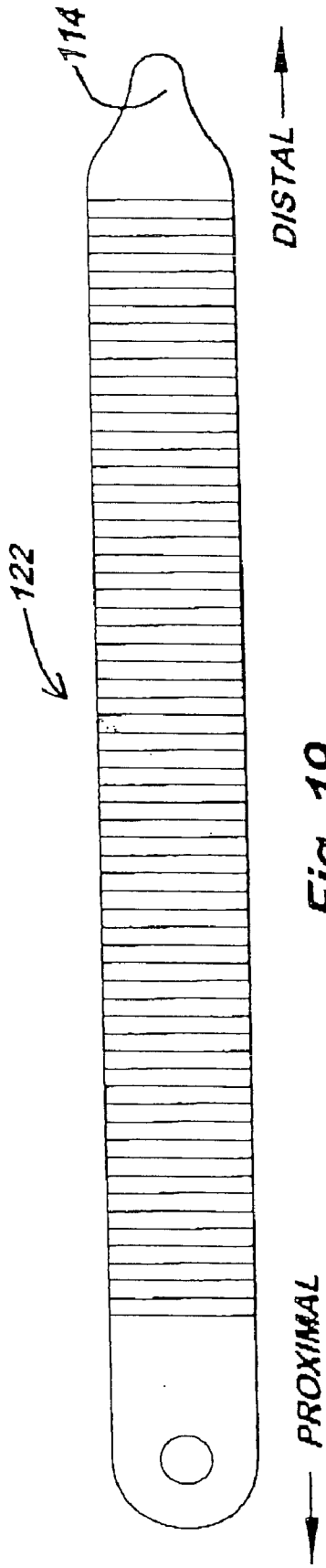

Fig. 19

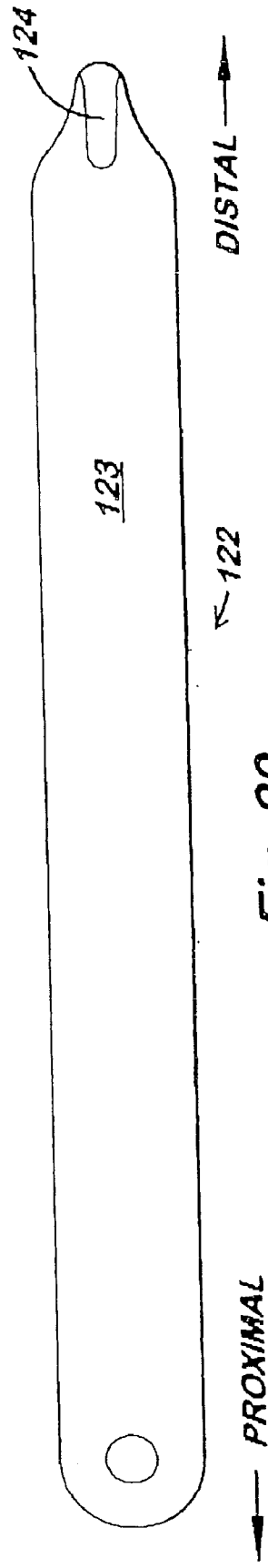

Fig. 20

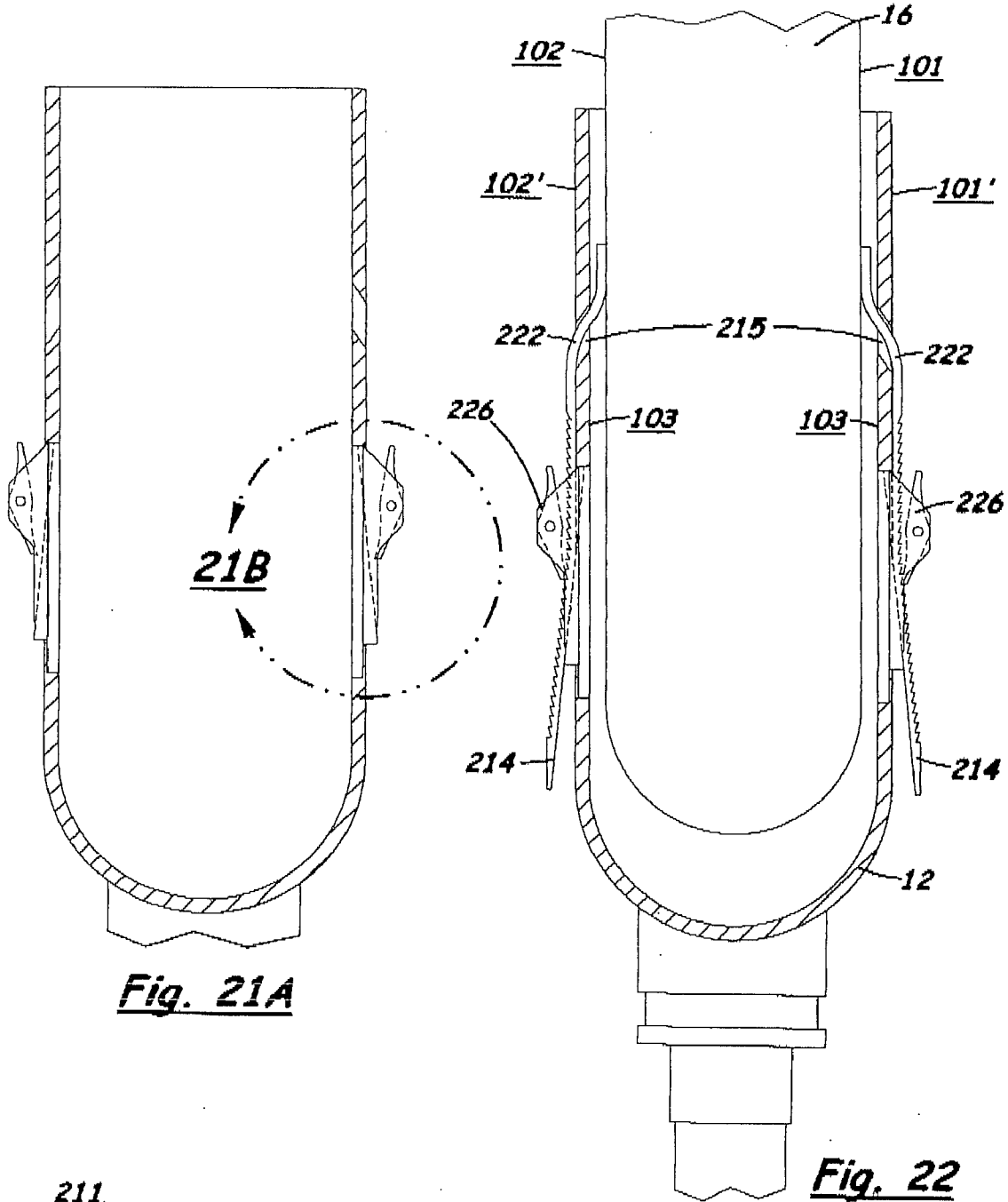

Fig. 21A

Fig. 22

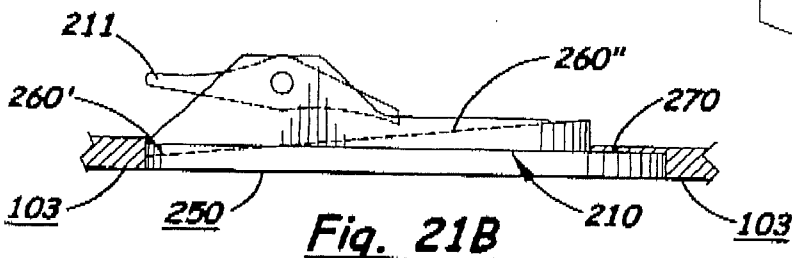

Fig. 21B

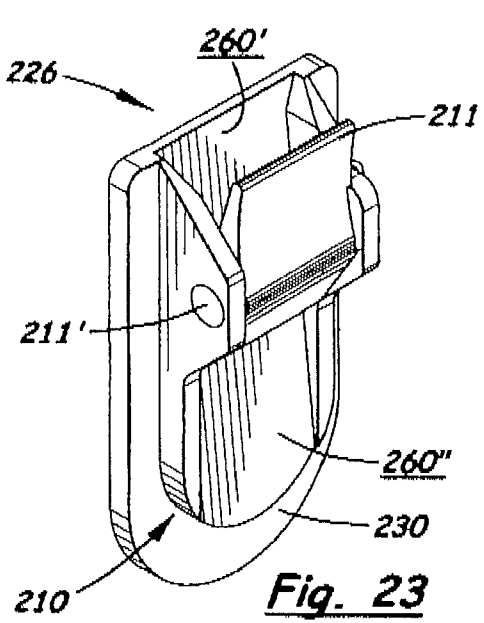

Fig. 23

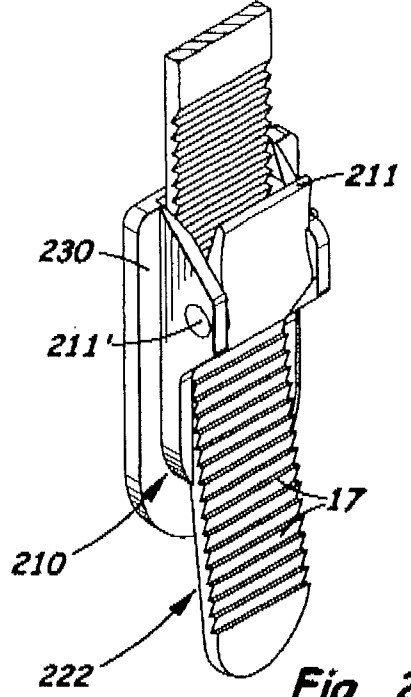

Fig. 24

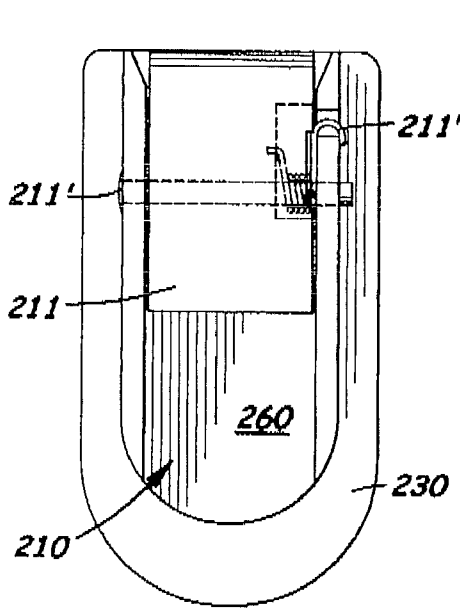

Fig. 25

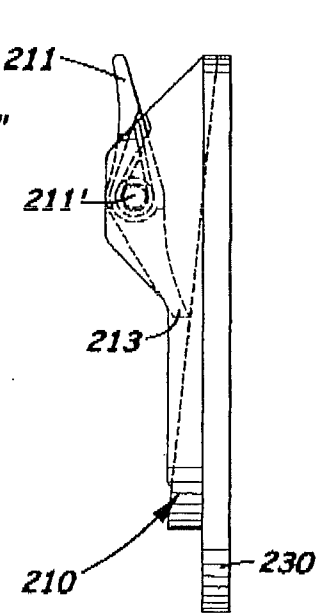

Fig. 26

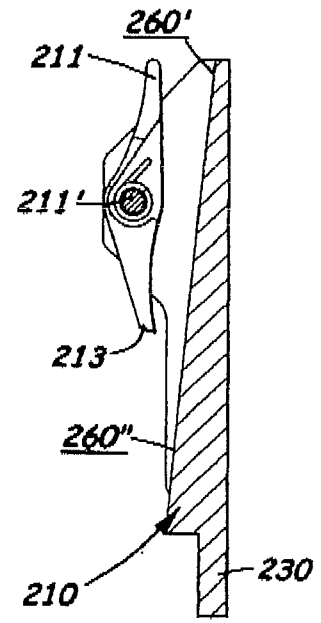

Fig. 27

ATTACHMENT SYSTEM FOR PROSTHESIS INCLUDING AXIAL TENSION STRAP ATTACHED TO SOCKET LINER

[0001] This application is a continuation of U.S. Non-Provisional patent Ser. No. 11/234,063, filed on Sep. 23, 2005, entitled "Attachment System for Prosthesis," issued Oct. 7, 2008 as U.S. Pat. No. 7,431,738, which is a continuation-in-part, and claims priority, of U.S. Non-Provisional patent application Ser. No. 10/746,208, filed on Dec. 23, 2003, entitled "Attachment System for Prosthesis," issued Jul. 18, 2006 as U.S. Pat. No. 7,077,868, which is a continuation-in-part, and claims priority, of U.S. Non-Provisional patent application Ser. No. 09/972,729, filed on Oct. 4, 2001, entitled "Attachment System for Prosthesis," issued Dec. 23, 2003 as U.S. Pat. No. 6,666,894, which claims priority of U.S. Provisional Patent Application Ser. No. 60/238,301, filed on Oct. 4, 2000, entitled "Attachment System for Prosthesis," the disclosures of which are incorporated herein by this reference.

Inventor:	Dale Perkins Twin Falls, Idaho	Matt Perkins Boise, Idaho
-----------	-----------------------------------	------------------------------

BACKGROUND OF THE INVENTION

[0002] 1. Field of the Invention

[0003] The present invention relates generally to prosthetics, and, more specifically to an attachment system used in the donning/doffing of a socket onto a residual limb. The present invention more particularly relates to an attachment system that requires little or no clearance inside the socket between the socket and the residual limb, that controls rotation of the prosthesis, and that may be used with a suction-fit socket system. The invented attachment system extends from the side of a liner on the user's limb, through an aperture in the socket, to the outer side of the socket, substantially proximal on the limb and on the socket relative to conventional more "distal" attachment devices. Therefore, the invented attachment may properly be called an exterior, proximal attachment device for a prosthesis.

[0004] 2. Related Art

[0005] For years, many different methods have been used to retain or "suspend" a prosthetic limb on an amputee's residual limb. Gravitational and other forces, for example, from movement of the limbs, tend to cause separation between the prosthetic limb and the patient's residual limb during use. This happens, for example, during the swing phase of gait, when a prosthetic leg is additionally subjected to centrifugal forces. Patients have routinely worn a variety of belts, straps, cuffs, and harnesses to retain their prosthetic limb against separation from the residual limb during these periods. However, such devices are often inconvenient and may tend to cause chafing against the patient's body, giving rise to sores and abrasions.

[0006] The manner in which a prosthetic limb is suspended and/or attached to the residual limb determines the amount of control an amputee has over the prosthesis. Therefore, by improving suspension/attachment without adding weight and excessive mechanism, the amputee may obtain improved comfort, convenience, and suspension mobility.

[0007] A common approach to tackling this problem has led to the design of a roll-on suction liner, which is rolled onto the residual limb and attached at its distal end to a socket or artificial limb. The liner, which is usually fabricated from silicone, or some other gel form, fits snugly over the residual limb, preferably completely covering the distal end of the residual limb and extending for at least several inches to cover the entire circumference of the proximal region of the residual limb. The liner, in turn, is enveloped, especially at its distal end, by the socket of the prosthesis, which is also called a "hard socket." A suction fit is preferably formed between the hard socket and the liner. This suspension method is very advantageous for the amputee. It gives the amputee the ability to better control the prosthesis and provides for useful sensory or proprioceptive feedback. Suction suspension also makes a prosthesis feel lighter, compared to other forms of suspension. Unfortunately, only a small percentage of amputees can successfully and comfortably wear a liner without another form of suspension. Therefore, the socket liner is typically equipped with a detachable component, at its distal end, which mates with a locking device in the interior of the socket at the bottom of the interior space or "well." This system secures the distal end of the residual limb/liner to the distal end of the artificial limb socket well, and, hence, is called a "distal attachment." The locking device in the distal end of the socket well typically employs a spring-loaded clutch mechanism or a pin-lock mechanism. The component on the distal end of the liner is typically a cylindrical barb-shaped structure or frictionally-retained pin.

[0008] One problem associated with such designs is the tugging or pull on the distal end of the limb. Most of these locks are not air tight, thus allowing air to flow into the hard socket and to eliminate the "suction." When this happens, the only suspension is the pin, which is a traction suspension, rather than a suction suspension. In cases where prosthetic socks are worn outside the liner, there is a risk the user's limb will become trapped in the socket if the sock is caught in the locking device. In these incidents, most patients are forced to make emergency trips to their practitioner to remove the prosthetic. Also, the locking device and attachment component cooperate in such a way to permit the barb or pin to lock in a plurality of longitudinal positions, which affects the overall length of the prosthesis. This can make it difficult for the patient to consistently achieve the same prosthetic configuration when the residual limb and the artificial limb are articulated. It should be further noted that, by weight of the lock being added at the distal end of the residual limb or near the distal end of the socket, this can make the prosthetic device feel heavier because of a "lever arm" effect, than if the same weight were placed more proximally. Additionally, many amputees, whether because of the length of their residual limb or their height, do not have room in the suction liner-socket-prosthesis combination for a distal locking mechanism. Or, additionally, use of a distal lock may limit what other prosthetic components that patient may use.

[0009] Despite the large number of suspension options available, none of the above-mentioned devices act to eliminate rotation between the hard socket and the suction liner. In an attempt to alleviate the rotation problem, a design called a "quad socket" has been used for many years. The quad socket is shaped in a square manner more than a cylindrical manner, and forcing the "cylindrical" limb to fit tightly in this square receptacle makes the prosthesis less apt to rotate on the limb, much as if you made a wheel square. Unfortunately, this is not

a very comfortable position for the limb. Today, there has been a trend toward more naturally-shaped sockets, making rotation control even more difficult.

[0010] Therefore, there is still a need for an improved attachment system for prosthetics. Also, there is a need for improving retention of the stump in the socket without sacrificing the patient's comfort and without comprising on expense, weight and simplicity of use of the prosthesis. There also is a need for improving rotation control, which will improve the patient's overall comfort and agility.

SUMMARY OF THE INVENTION

[0011] The present invention is an attachment system and methods for connecting a prosthesis to a residual limb of the user. Preferably, the attachment system extends from the side surface of a liner on a residual limb to the outside side surface of a hard socket fitted around the liner and limb. Preferably, the attachment system includes a strap system that connects to the outer side surface of the liner to the socket, wherein said strap extends into the socket along a portion of the limb, and through an aperture in the sidewall of the socket. Preferably, the strap further extends to a buckle or other latch mechanism connected to the socket, typically about midway or more, proximally, on the outside surface of the socket. At least a portion of the buckle or other latch mechanism may be at the outside surface of the socket and accessible to the strap. In some embodiments, an externally mounted buckle may be easily reached and maintained by the user, and easily retrofit as an add-on feature to existing hard sockets. In some embodiments, an internally mounting the buckle/latch mechanism may lower its profile, increasing the ease with which the strap connects to the buckle/latch mechanism, as well as being more aesthetically pleasing. In this way, a combination of the invented prosthetic attachment system and suction fit provide superior retention of the artificial limb on the user.

[0012] The preferred strap system includes a disk member or "umbrella" that may be adhesively secured to the surface of the liner, and an elongated strap that extends distally from the umbrella and longitudinally a short distance along the side surface of the limb. The strap may be secured to the umbrella in such a way that its exact angle relative to the limb's longitudinal axis may be adjusted as desired and then locked in place, for example, by tightening of a bolt. The lock is preferably a buckle-style latch mechanism, with a spring-biased member and one or more sharp edges, that frictionally engage transverse detents located between transverse raised ridges on the strap's surface. Thus, the strap is inserted into the buckle to the extent desired by the user, and, in a ratchet-like action, the sharp edge wedges into the transverse detents and secures the strap from being pulled out or away from the buckle. Thus, the strap is anchored in the buckle, and the socket is held closely on the residual limb until the user chooses to unbuckle the buckle.

[0013] The especially preferred embodiment includes a dual strap and buckle system wherein one strap and one buckle are located on the medial surface of the liner and socket respectively and one strap and one buckle are located on the lateral surface of the liner and socket respectively. The especially preferred embodiment also includes the invented strap and buckle system wherein said strap may have a "nipple" shaped tab extension at its most distal end to facilitate the strap through the buckle. The underside of the said strap may have a small grooved channel at its distal end in order to feed the strap over a rivet in the base of the buckle.

[0014] Therefore, the prosthetic attachment system is easily accessible, effective, simple, and easy to use. The versatility and simplicity, and non-interfering design of the invented prosthetic attachment system helps provide reliable and comfortable suspension for an artificial limb on a great number of persons with limb deficiency.

BRIEF DESCRIPTION OF THE DRAWINGS

[0015] FIG. 1 is a close-up, lateral view one embodiment of the prosthetic attachment system according to the invention, installed on a user's residual limb.

[0016] FIG. 2 is a lateral view of the preferred prosthetic attachment system showing the strap as it enters the inside of the socket.

[0017] FIG. 3 is a lateral view of the preferred prosthetic attachment system showing the strap after it has entered the socket and as it passes through an opening in the socket to the socket's outer surface.

[0018] FIG. 4 is a lateral view of the preferred prosthetic attachment system showing the strap after it has entered the buckle.

[0019] FIG. 5 is a lateral view of the preferred embodiment after the prosthetic is installed on the user's residual limb, showing the foot.

[0020] FIG. 6 is a side view of one embodiment of the buckle-style latch mechanism of the present invention.

[0021] FIG. 7 is a top view of the lever of the buckle of FIG. 6.

[0022] FIG. 8 is a top view of the buckle of FIG. 6.

[0023] FIG. 9 is a frontal view of the base frame of the buckle of FIGS. 6 and 8.

[0024] FIG. 10 is a side view of one embodiment of the lever of the buckle of FIGS. 6 and 8.

[0025] FIG. 11 is a frontal view of the pin of the buckle of FIGS. 6-10.

[0026] FIG. 12A is a plan view of one embodiment of an umbrella plate for attachment to an outside surface of a liner.

[0027] FIG. 12B is a side view of one embodiment of a strap according to the invention, for cooperating with, and connecting, the buckle-style lock and the umbrella plate.

[0028] FIG. 13 is a ventral view of the especially preferred embodiment of the prosthetic attachment system showing two straps located laterally and medially.

[0029] FIG. 14 is a close-up, lateral view of the especially preferred embodiment of the prosthetic attachment system of FIG. 13.

[0030] FIGS. 15-17 are sequential, lateral views of the especially preferred embodiment of the prosthetic attachment system of FIGS. 13 and 14 depicting the process of installing a prosthetic on a residual limb.

[0031] FIG. 18 is a detail side view of the strap of FIGS. 13-17 in relation to the buckle of FIGS. 13-17, before the strap is inserted in the buckle.

[0032] FIG. 18A is a detail side view of the strap of FIGS. 13-18 in relation to the buckle of FIGS. 13-18, after the strap is inserted in the buckle.

[0033] FIG. 19 is a top view of the especially preferred embodiment of the strap of FIGS. 13-18.

[0034] FIG. 20 is a bottom view of the especially preferred embodiment of the strap FIGS. 13-19.

[0035] FIG. 21A is a front view of another embodiment of a prosthetic attachment system according to the invention, which features one embodiment of low profile buckles mounted internally and extending through the socket.

[0036] FIG. 21B is a close-up detail view of one of the buckles of FIG. 21A.

[0037] FIG. 22 is a front view of one embodiment of a prosthetic attachment system, wherein a residual limb with a liner is inserted into the socket of FIGS. 21A and B and one embodiment of a strap according to the invention extends from the liner, through the socket, and to the buckle to suspend the socket from the liner and limb.

[0038] FIG. 23 is a perspective view the low-profile buckle of FIGS. 21A, 21B, and 22.

[0039] FIG. 24 is a perspective, partial view of the buckle of FIGS. 21A, 21B, 22, and 23, receiving the strap of FIG. 22.

[0040] FIG. 25 is a front view of the buckle of FIGS. 21-24.

[0041] FIG. 26 is a detailed side view of the buckle of FIGS. 21-25.

[0042] FIG. 27 is a cross-sectional view of the buckle of FIGS. 21-26.

DETAILED DESCRIPTION OF THE INVENTION

[0043] Referring to the Figures, there are shown several, but not the only, embodiments of the invented prosthetic attachment system. In this Description and the Claims, the term “proximal” means toward the center/torso of the body, and so toward the top/upper end of the liner and prosthetic device. Thus, in the case of a prosthetic device for a person’s leg, “proximal” would mean nearer or toward the upper thigh and trunk. “Distal” means away from the center/torso of the body, and so the regions of the liner or prosthetic device farther out from the trunk, and farther out on the leg.

[0044] Referring to FIGS. 1-12B, buckle 26 includes base 10, which is mounted on the external surface of the hard socket 12 by means of a rivet 20, glue or other fastener, or it may even be molded integrally with the socket 12. The buckle 26 is positioned proximally higher up the socket than conventional “distal” locks that are mounted near the distal end of the socket, typically at the bottom of the inside “well” of the hard socket 12. Connected to base 10 are a lever 11 and pin 11' with e-clips 11", which together create a biased system for receiving and capturing strap 22, as seen in FIGS. 8 and 12B. Strap 22, as discussed below, is preferably secured to the liner 16, by means of an umbrella 18 (see FIG. 12A), and is long enough to comfortably and conveniently extend from the middle to upper region of the side of the liner to reach the lower region of the liner (see FIG. 2).

[0045] Liner 16 may be a custom or a pre-manufactured liner as described in the Related Art section above. Examples of currently-available conventional liners are ICEROSS, ALPHA, LUXURY LINER, ALPS, SILIPOS (all trademarks). Modern urethane liners are especially preferred. As is well-known in this field, the currently-available liners listed above are examples of interface liners that are positioned between a residual limb and a prosthetic socket and are frequently called “suction liners,” “gel liners,” or “roll-on liners.” These liners typically are rolled-onto the residual limb for a suction, slight compression, and/or gripping connection of the inner gel layer of the liner to the skin of the residual limb. The liner-covered limb is then inserted into the prosthetic socket, and the outer surface/layer of the liner preferably forms a suction, grip, or other interference fit to the socket to interfere with the socket falling off the limb. The liners called by these names (“suction liners,” “gel liners,” or “roll-on liners”) include the modern “second generation” liners currently preferred by most wearers of prosthetics, which include a textile/fabric outer layer, as well as the older, “first

generation” liners that typically did not have a textile/fabric outer layer. The term “suction liner” is still used by many manufacturers, prosthetic technicians, insurance and medicare/medicaid entities, and wearers of prosthetics, even though the modern liners, with their textile/fabric outer layers, do not form what would be called “true” or “pure” suction with the socket. See, for example, discussion of suction liners in Janusson, et al. (U.S. Pat. No. 6,706,364) and Janusson, et al. (U.S. Pat. No. 6,626,952).

[0046] Strap 22 is connected at its proximal end to liner 16, preferably by an umbrella 18 or other fixture or bracket. The umbrella 18 may be glued to the liner, as seen in FIG. 2. Umbrella 18, as shown in FIG. 12A, is preferably an aluminum plate structure of approximately 3/4" in diameter and 1/4" thick, with preferably a slightly-concave inner surface for contacting the glue, and with apertures at various locations on the umbrella to assist in receiving and better gripping of the glue that connects the umbrella 18 to the liner’s 16 outside side surface. However, umbrella 18 may also be sewn onto or into liner 16, or it may be formed integrally with liner 16. Also, alternatively, other shapes of an attachment plates or other attachment means may be used instead of the umbrella, as long as preferably they are thin and easily slide/fit into the socket.

[0047] The strap 22 is attached to the umbrella 18, for example, with a 1/24-spanner bolt or screw. The screw is then tightened down to the umbrella 18, rather than allowing the strap 22 to pivot around the screw. This results in the strap 22 being adjustable, allowing the user or prosthetist to move the strap 22 and then lock it into the optimum position, even if the strap 22 or lock mechanism have been attached to their respective structures in less-than-perfect position or location.

[0048] When hard socket 12 is installed on the residual limb, it extends up over and around liner 16 and umbrella 18, as shown in FIG. 1. Strap 22 extends from umbrella 18 on liner 16 a short distance on the inside of socket 12 through an aperture 15 in socket 12 to the external surface of socket 12 (see FIGS. 2 and 3). There, the strap 22 continues to extend to and through the preferred buckle 26 attached on the outside surface of the socket 12, as shown in FIG. 4. The buckle 26 adjustably receives the distal end of the strap 22, by means of the strap 22 extending through the buckle 26 between the base 10 and the lever 11. The strap 22 is pushed/pulled through the buckle 26 to the point where the hard socket 12 is securely, but comfortably secured around and connected to liner 16 via the strap 22 and umbrella 18 combination. This way, the advantages of the invention are realized.

[0049] Strap 22 is preferably sufficiently rigid, sufficiently long, and is positioned so that, upon the limb/liner being inserted into the socket, the strap naturally tends to slide to and through the aperture 15, to the buckle 26, and through the buckle 26 with little or no need for the user to thread or pull the strap 22 through the aperture 15 or buckle 26. A prosthetist will be able to adjust the strap and/or buckle locations and aperture size to enable this smooth movement and latching of the strap in the buckle. Optionally, the socket wall surface, on the interior or exterior, may be contoured to facilitate and direct the strap.

[0050] The release button of the buckle 26 is buckle lever 11, which features sharp edge 13, as shown in FIG. 7. The top surface of base 10 ramps up in thickness in the distal direction. This provides for easier strap 22 entry into the buckle-style latch mechanism, and increasing pressure on the strap 22 when engaged by means of the buckle lever 11 pressing/

ratcheting against the strap 22. Edge 13 engages the sharp “ratchet teeth” of strap 22, extending into the transverse detents 17 and abutting against the teeth walls upending from the strap top surface (see FIG. 12B). Any pull on the strap 22 in the proximal direction is resisted by the engagement of edge 13 in detents 17 and the pressure of lever 11 against c-clips 11". The attachment system may be placed in a position on the liner and socket that the prosthetist deems most advantageous and convenient for the patient. The mechanism is attached to the exterior of the socket at a location determined by test socket fitting, but in any event, not at the distal end of the socket. Typically, when a single attachment system is employed, it will be placed in a lateral position so that the user may reach it by reaching toward the outside of his limb.

[0051] After mounting of the base 10 of the buckle 26 onto the socket 12, the umbrella 18 onto the liner 16, and strap onto the umbrella 18, the roll-on prosthetic liner 16 of choice is applied to the patient. The patient can then step into the hard socket 12 and engage the attachment system, by inserting the strap 22 through the aperture 15 and into the buckle 26. This procedure may be used in the retrofitting of the attachment system to an existing prosthetic.

[0052] If a new prosthetic is being created, the liner 16 is applied to the patient, and the ideal location for the umbrella 18 is marked on liner 16. A mold over the patient’s limb and liner 16 is then taken. After the mold and liner 16 are removed, the umbrella 18 is then attached to the liner 16 in the location marked. From the mold the hard socket 12 is created, and the base 10 of the lock mechanism is attached in the proper location on the outside of hard socket 12, and then the aperture 15 is created in hard socket 12 as above.

[0053] The aperture 15 or any other opening through the socket preferably may be easily sealed by a gel suction wrap/cover, or other air-tight wrap or plug that preferably encases the lock mechanism and aperture. This allows and maintains a “suction” fit between the socket and the liner that improves the function of the prosthetic.

[0054] As shown to best advantage in FIGS. 2-5, after donning of the prosthetic, the roll-on liner proximal wall extends generally parallel to the socket proximal wall, and the liner extends above the upper extremity edge of the socket while the strap at its attachment to the liner proximal wall is inside the socket.

EXAMPLE

[0055] The above attachment system was fit to three test patients. All three of these patients utilized ALPHA™ liners in a normal manner. The locking tab was attached to the ALPHA™ liners in a normal manner. Two of these patients were unilateral transtibial amputees, and one patient was a unilateral congenital above-knee amputee. The above-knee amputee was a congenital amputation resulting from PFFD, and his amputation level was consistent with a knee disarticulation level. All three of these patients either demonstrated problems with conventional distal pin-lock systems, or, in the case of the transfemoral amputee, did not have sufficient room to install any of the distal locking mechanisms currently on the market. These patients were using the prosthetic lock suspension according to the present invention on their prosthesis on a daily basis. These patients were all experimentally fit in June of 2000 and no problems were encountered with mechanical failures or with patient acceptance or satisfaction. We continue to monitor these patients at 2-3 week intervals.

[0056] One may see, after reviewing the disclosure of this Description and the Drawings, that the invented attachment system tends to prevent rotation of the prosthesis on its longitudinal axis (axis extending between its proximal end and distal end) relative to the amputated limb. By providing one of the invented side-located, “proximally-located” attachment systems, such rotation is limited or prevented. This is because the strap extends from a fixed anchor location on the side of the liner/limb to a fixed anchor location on the side of the socket, thus connecting those two fixed locations together at substantially a fixed distance apart, thereby not allowing the anchor location on the socket to rotate any significant distance away from the anchor location on the liner. Although one of the invented attachment systems is preferred, more than one may possibly be used, for example, at two positions around the side of the limb/socket, as described below.

[0057] Other benefits of the attachment system include comfort and ease of use. The preferred attachment system is simple to use, each to reach, and requires a minimum of dexterity. The externally-mounted lock mechanism eliminates the jamming of conventional distal locks often caused by a sock worn over the roll-on liner.

[0058] While a ratchet-style buckle and strap combination is preferred, other releasable attachments and fasteners may be used. For example, extension members other than a flat strap with detents may be used, such as a cord(s), loop(s), tab(s), or other rigid or flexible extension members. Latch mechanisms other than a buckle may be used, such as a hook(s), clip(s), snap(s), or other devices that adjustably or non-adjustably grip the extension member. The connection between the extension member and the latch mechanism is preferably, but not necessarily, adjustable. This permits the user or the prosthetist to manipulate the connection for optimum use and comfort, either by lengthening or shortening the connection or by pivoting or otherwise moving the location of the extension member or latch mechanism.

AN ESPECIALLY PREFERRED EMBODIMENT

[0059] In the Description and Claims, the term “lateral” means on/toward the outer surface or region of the body, and therefore, on/toward the outer surface or region of the apparatus that is installed on the human body. Thus, a lateral surface of the liner or socket is an outer side surface, away from the inner or medial plane of the body. See lateral surfaces 101, 101' of the liner and socket, respectively, in FIGS. 13 and 14, wherein the apparatus is on the left leg and FIG. 13 is a ventral (front) view. The term “medial” means on/toward the inside or medial plane of the body. Thus, a medial surface of the liner or socket is an inner side surface, away from the outside of the body. See medial surfaces 102, 102' of the liner and the socket, respectively, in FIG. 13, wherein the apparatus is on the left leg.

[0060] Referring to FIGS. 13-17, attachment systems are shown with improved straps and latch mechanisms that make donning and doffing the prosthesis more convenient and comfortable. The embodiment of FIGS. 13-17 comprises two straps 122, one attached to the lateral surface 101 of the liner 16 and one attached to the medial surface 102 of the liner 16, as shown in FIG. 13. These two straps are secured to the liner by means of an umbrella 18 described above and shown in FIGS. 1-12B.

[0061] The especially preferred strap 122 has a “nipple” shaped tab extension 114, or other tapered, narrow tip, at its distal end. The extension 114 preferably has a width less than

half of the width of the strap 122. The extension facilitates the strap 122 from the inside of the socket 12 to the socket's external surface and through the buckle 126 (see FIG. 19). The bottom surface 123 of the especially preferred strap 122 may have a longitudinal channel 124, or other groove or ramp-like shape at the distal end, to prevent the strap 122 from "catching" on the rivet 20 in the base 110 of the buckle 126. The thinness (from top surface to bottom surface) of the central region of the distal end, caused by the channel 124, aids in smooth insertion of the strap 122 into the buckle 126, and allows the distal end to slide over the rivet 20. This way, the rivet 20 need not be lowered or countersunk into the base 110. Alternatively, the entire bottom surface of the distal end of the strap may be slanted/thinned, but this would result in a weaker distal end.

[0062] In order to install the socket 12 on the residual limb, the user places the two straps 122 inside the socket 12 and then feeds them through two apertures 115 located medially and laterally in the socket's 12 side wall, as seen in FIGS. 15 and 16. Once the tabs 114 of the straps 122 exit the apertures 115 to the external surface of the socket 12, they feed into two buckles 126, distal from the apertures 115, on the medial and lateral surface of the socket 12 (see FIGS. 16 and 17). Preferred buckle 126 may include a spring-biased member with one or more sharp edges 113, that frictionally engage transverse detents 17 located between transverse raised ridges on the strap's surface. Connected to each base 110 of the buckles 126, are a lever 111, pivot axle pin 111', and e-clips 111" or other biasing spring or member, which together create a biased system for receiving and capturing the straps 122. The top surface of each base 110 ramps up towards the distal end of the buckle 126, allowing easy insertion of the straps 122, as shown in FIG. 18. As the distal end of each strap 122 moves into the proximal end of each buckle 126, the sharp edge or edges 113 of the buckles 126 engage the transverse detents 17 of the straps 122 (see FIG. 19). The channel 124, on each strap 122, bypasses the rivet 20 in base 110 of its respective buckle 126, allowing the distal end strap 122 to exit the distal end of the buckle 126, in turn securing the socket 12 to the residual limb (see FIG. 19).

[0063] The preferred method for releasing the straps 122 from the buckles 126, is for the user to pull up on the distal end of each lever 111 to pivot the lever 111 into a raised position as shown in FIG. 18A, which corresponds to pivoting the distal end of the lever 111 away from the socket. This, in turn, disengages the sharp edge or edges 113 of each buckle 126 from the transverse detents 17 of each strap 122 (see FIGS. 18 and 19). The user is then able to remove the socket 12 from the residual limb by holding on to each lever 111 and pulling the socket 12 off the liner and also by maneuvering his/her residual limb out of the socket. Having a plurality of attachment systems for a single prosthetic device may improve stability and comfort for the user. By utilizing lateral and medial strap and buckle combinations, rotation of the prosthetic device relative to the user's residual limb is minimized, if not prevented. Further, the levers of the lateral and medial buckles provide a hand-hold for the user, especially during removal of the socket from the liner-covered residual limb. The lift-to-release buckle levers may be easier to operate and may provide a better hand-grip for the user, compared to the embodiment of FIGS. 1-12B which requires that the user push and hold down the levers of the buckles during removal of the prosthesis.

[0064] The buckles illustrated in FIG. 13 are depicted to be quite large and to protrude significantly from the socket, but the buckles may be made to small and low-profile, so that the strap and buckle combination is discreet when covered by clothing and comfortable for walking without the buckle catching on the other leg or clothing.

A Low Profile Buckle Embodiment

[0065] Alternative buckles may be made to be small and/or low-profile, so that the strap and buckle combination is discreet when covered by clothing and comfortable for walking without the buckle catching on the other leg or clothing.

[0066] One way of establishing a low-profile system is to locate at least a part of a buckle/latch mechanism(s) inside the socket wall, rather than on the socket wall. For example, a portion of the buckle may be recessed into the socket wall from the outer surface, but, more preferably, at least a portion of the buckle extends through the socket wall from at or near an internal surface of the socket. Either way, the buckle is, in effect, "sunk" into the socket rather than resting on the outer surface of the socket, so that the strap enters the buckle closer to the outer surface of the socket and the buckle protrudes from the socket to a lesser amount. The preferred buckle has only about 25-50%, and more preferably about 25%, of its thickness above the plane of the outer surface.

[0067] Referring to the embodiment shown in FIGS. 21-27, one or buckles 226 are mounted in the socket by inserting the buckle 226 through an opening in the socket wall. The buckle extends through the wall to protrude slightly beyond the external surface of the socket. Strap 222 may enter the buckle at or near the plane of the external surface of the socket; and the buckle may protrude minimally from the socket, so that it tends not to catch on the user's clothing or other leg, and tends to be less noticeable.

[0068] Preferably, two straps 222 and two buckles 226 are used. The straps 222 are attached to the lateral surface 101 and medial surface 102 of the liner 16, respectively, as shown in FIGS. 21A and 22, by an "umbrella" or other attachment. The buckles 226 extend through the wall of the socket, with the bottom surface 250 of the buckle preferably being coplanar with the inside surface 103. Top surface 260 of the buckle, which is configured for receiving the strap, is preferably approximately coplanar with the lateral or medial outside surfaces 101', 102' of the socket near the buckle. One may understand that, due to the typically generally-cylindrical shape of the inner and outer surfaces of the sides of the socket, neither the inner or outer surfaces are expected to be exactly planar in the region of the buckle. However, given the relatively small size of the preferred buckles (less than about 1.5 inches in width transverse to the length of the socket), one may still say that the bottom surface 250 of the buckle is generally parallel to the plane of the inner surface 103 of the socket, and one may still say that the top surface 260 (which is typically planar but slanted/ramped) is generally parallel to the plane of the outer surface 101', 102'. In this discussion, "top" is used to refer to the surface 260 across which the strap slides or otherwise moves, and "bottom" is used to refer to the opposing surface, as this is convenient in view of the orientation of the buckle 226 when it is set, for example, on a table prior to installation. This terminology is not intended to limit the orientation of the buckle when installed in the prosthetic system, however.

[0069] Buckle 226 preferably comprises base 210 having a flange 230 around at least part of the base. The flange 230 is

thinner than the main body of the base **210** and thinner than the thickness of the socket wall. This way, the flange lies within the wall of the socket but does not extend all the way through the wall, so that a portion of the socket wall (such as lip **270**) extends over the flange to help prevent the buckle from being pulled out of the socket wall from the outside of the socket.

[0070] Connected to the base **210** are a lever **211** and pin **211'** with resilient e-clips **211"**, which together create a bias system generally located over, and cooperating with, top surface **260** to retain strap **222** in the buckle. As shown to best advantage in FIGS. **22** and **24**, the top surface **260** of the base **210** ramps up slightly in thickness in the distal direction. Proximal end **260'** of the top surface is at or slightly below the plane of the outer surface of the socket wall, to assist in easy sliding of the strap into the buckle from the distal region of the socket. Distal end **260"** of the top surface is farther out from said plane for better clamping of the strap between the top surface **260** and the bias system and for placing the end of the strap slightly distanced from the outside of the socket in a position that is easily reachable by the user (FIG. **22**).

[0071] The lever **211** acts as both the securement device for fastening the strap **222** in the buckle **226**, as well as the release button to allow release the strap **222** from the buckle **226**. The lever **211** preferably comprises a generally sharp edge **213** at its distal end. The edge **213** engages the "ratchet teeth" of strap **222** by extending into the transverse detents **17** and abutting against the teeth walls upending from the strap top surface. A pull on the strap **222** in the proximal direction is resisted by the engagement of edge **213** in detents **17** and the pressure and bias of lever **211** against e-clips **211"**.

[0072] The preferred, but not the only, method of installing buckles **226** through the wall of the socket **12** is as follows. The socket **12** is molded with a dummy piece in the place where the buckle **226** will be inserted, wherein the dummy piece will typically be about the width and length of the base without its flange. This typically results in the space for the buckle substantially being "reserved" so that the laminate materials used to make the socket do not fill said space. A thin layer or layers of laminate over the outer surface of the dummy piece may form and remain after the molding, which layer/layers may be drilled or cut away so that the dummy piece may be "popped out" the exterior of the socket. After the dummy piece is removed, the wall around the dummy-created hole is modified to receive the flange, that is, so that the wall has step or lip **270** extending over the hole at the outer perimeter of at least some areas of the hole. This way, the buckle base may be inserted into the stepped hole, with the flange retained by the lip **270** and with the ramped top surface being exposed on/near the outside of the socket and the bias system protruding from the socket.

[0073] At least a portion of the base is adhered to the interior surface **103** of the socket, for example, the flange **230** is preferably adhered to the lip **270** by glue, other adhesive, or other securement means. A rivet, screw, or other fastener may be used to secure various embodiments of the buckle in the wall of the socket, for example, a rivet through the flange **230** and t-rough the lip **270**. Instead of such hardware, however, it is preferred that the dimensions of the buckle be formed to make it unlikely that it will be pulled out of the socket by the strap and that adhesive further ensures this and also keeps the buckle in place in the wall when there is no force being applied to the buckle by the strap.

[0074] Strap **222** is preferably sufficiently rigid, sufficiently long, and is positioned so that, upon the limb/liner being inserted into the socket, the strap naturally tends to slide to and through the aperture **215** in the socket, to the buckle **226**, and through the buckle **226** with little or no need for the user to thread or pull the strap **222** through the aperture **215** or buckle **226**.

[0075] Strap **222** optionally may have a tapered, narrow, or otherwise specially-shaped tip or extension at its distal end, to assist in the strap **222** easily moving through the aperture **215**, and along the buckle; this is not known in FIGS. **21-27**, but one embodiment is shown in FIGS. **13-20**. Such a tip or extension facilitates the strap from the inside of the socket **12** to the outside of the socket and through the buckle because the tip/extension tends to center the strap as the tip/extension enters the aperture or buckle.

[0076] Also in a similar manner as described for the strap shown in FIGS. **13-20**, the bottom surface of strap **222** may have a longitudinal channel, or other groove or ramp-like shape especially at the distal end, to prevent the strap **222** from "catching" in the base **210** of the buckle **126**. This may be helpful, especially in the case of the buckle comprising a rivet or other fastener that might get in the way of the strap **222**, but, for the preferred low-profile buckle with proximal surface **260'** being recessed relative to the surrounding outer surface of the socket, the channel or groove in the bottom surface of the strap is typically not as necessary.

[0077] In order to install the socket **12** on the residual limb, the user places the two straps **222** inside the socket **12** and then feeds them through two apertures **215** located medially and laterally in the socket's **12** side wall, as illustrated by FIGS. **21** and **22**. Once the ends of the straps **222** exit the apertures **215** to the external surface of the socket **12**, they tend to automatically feed into two buckles **226**, distal from the apertures **215**, on the medial and lateral surfaces of the socket **12** (see FIGS. **21** and **22**).

[0078] The preferred method for releasing straps **222** from the buckles **226**, is for the user to push down on the proximal end of each lever **211** to pivot the lever **211** from the "lowered position" of FIG. **26** into the "raised position" as shown in FIG. **27**, which corresponds to pivoting the distal end of the lever **211** away from the socket **12**. This, in turn, disengages the sharp edge or edges **213** of each buckle lever **211** from the transverse detents **17**. The user is then able to remove the socket **12** from the residual limb, preferably by continuing to keep the buckles unlatched by pushing on the proximal end of the lever **211**, by pushing the socket **12** off the liner **16**, and also by maneuvering his/her residual limb out of the socket **12**.

[0079] Alternatively, lift-to-release buckle levers, for example, as illustrated in FIGS. **13-18**, may be easier to operate than push-to-release levers for some users and may provide a better hand-grip for some users. The inventors envision that both styles may be used in embodiments of low profile buckles.

[0080] While lateral and medial positions for two strap and buckle combinations are preferred, a single strap and buckle combination may add prosthetic stability and operability for many users. Alternatively, other numbers and arrangements of straps and buckles/latch mechanisms may be effective.

[0081] Preferred levers **11**, **111**, and **211** are deemed to be convenient and reliable for latching and unlatching their respective buckles, and preferably, each lever is biased into the latched position and requires positive action by the user or

prosthetist to unlatch it. However, other styles of latch mechanisms may be used, such as other pivotal arms or hooks, snaps, clips, loops, ties, or other releasable locks and latches. [0082] Preferably, the prosthesis attachment system comprises the invented extension member and latch system, with or without the aid of suction between the liner and the socket, but no other straps or attachments. Preferably, there is no belt or strap extending to encircle part of the user's body, and preferably no attachment between the distal end of the limb/liner and the bottom of the well of the socket.

[0083] Although this invention has been described above with reference to particular means, materials and embodiments, it is to be understood that the invention is not limited to these disclosed particulars, but extends instead to all equivalents within the broad scope of this disclosure and the following claims.

- 1. A leg prosthesis comprising:
 - a prosthesis comprising a socket for receiving a residual limb of a user and a prosthetic foot, the socket having a socket distal end and a socket proximal side wall surrounding and defining an interior well receiving the residual limb, and said socket proximal wall having an aperture and an upper extremity edge, the socket having an axial dimension extending between said tipper extremity edge and said socket distal end;
 - a roll-on liner having a liner distal end and a liner proximal side wall, said roll-on liner configured to secure to the residual limb by being rolled-on to the residual limb so that the liner snugly covers the entire circumference of the residual limb, and said roll-on liner, when rolled-onto the residual limb, being received in the socket so that the liner proximal wall extends generally parallel to the socket proximal wall;
 - a strap connection system having an extension member anchored at one end to said liner proximal wall at a location below the socket upper extremity, extending axially through said aperture in the socket proximal side wall, extending axially along an outside surface of the socket proximal side wall, and connecting to a lock between said socket distal end and said upper extremity edge of the socket proximal wall, wherein said lock is below said aperture;
 - wherein the prosthesis is suspended from the residual limb by said roll-on liner gripping the residual limb, and said strap connection system holding the socket on said liner, and wherein the prosthesis comprises no belt or strap configured to encircle part of the user's body.
- 2. A leg prosthesis as in claim 1, wherein the lock is mounted to the outside surface of the socket.
- 3. A leg prosthesis as in claim 1 wherein the lock is a buckle having a biasing lever and a base with a ramped top surface against which the biasing lever clamps the extension member.
- 4. A leg prosthesis as in claim 3, wherein the ramped top surface has a proximal region that is recessed into the socket proximal wall so that the extension member slides onto the ramped top surface without catching on said base.
- 5. A prosthesis system for connection to a user's residual limb, the prosthesis comprising:
 - a hard socket receiving a roll-on liner that is configured to be attached to a residual limb by being by rolling onto

- said limb and snugly surrounding the entire circumference of the limb, wherein said hard socket has a proximal extremity edge and a distal end and a longitudinal axis between said proximal extremity edge and said distal end, the proximal extremity edge for being nearer the user's torso and the distal end for being farther away from the user's torso when the hard socket is donned on the user's residual limb, and
- a tension suspension system comprising an axially-oriented strap attached to a proximal side wall of the liner inside the hard socket and extending distally downward and through an aperture in the hard socket so that it reaches and connects to a lock outside of the socket that is nearer to the distal end of the socket than is the aperture, so that said strap is in axial tension when connected to said lock.
- 6. A prosthesis system as in claim 5, comprising no waist belt adapted to connect the hard socket to the user's waist.
- 7. A prosthesis system as in claim 5, wherein the lock is mounted to the outside surface of the socket.
- 8. A leg prosthesis as in claim 1, wherein the liner proximal wall extends above the socket upper extremity.
- 9. A leg prosthesis comprising a hard socket, a prosthetic foot connected to the hard socket, and a roll-on liner, wherein:
 - the hard socket has an internal well for receiving a user's residual leg limb, a distal end, a proximal edge, a socket axial dimension between said distal end and said proximal edge, and a socket axial wall having a proximal region with a socket aperture extending from the well to an outer surface of the proximal region;
 - the roll-on liner being configured to secure to the user's residual limb by being rolled-on to the residual limb so that the liner snugly covers the entire circumference of the residual limb, the roll-on liner being received inside the hard socket well and having a liner distal end near the distal end of the socket, a liner proximal edge, a liner axial dimension between said liner distal end and said liner proximal edge, and a liner axial sidewall with a proximal region; and
 - the roll-on liner further comprising an extension member anchored at one end to said proximal region of the liner axial sidewall, extending axially and distally through said socket aperture, and extending axially and distally along said outside surface of the proximal region of the socket axial wall for connection to a lock outside the socket, wherein the socket is suspended from the residual limb by said roll-on liner gripping the residual limb and said extension member holding the socket on said liner, and wherein the leg prosthesis comprises no belt or strap configured to encircle part of the user's body.
- 10. A leg prosthesis as in claim 9, wherein the roll-on liner comprises an inner gel layer and an outer fabric layer.
- 11. A leg prosthesis as in claim 9, wherein the extension member comprises a disk secured to a surface of the roll-on liner, and an elongated strap that extends distally from the disk.

* * * * *